

HAMILTON-C1

Quick Guide

HAMILTON
MEDICAL

Intelligent Ventilation since 1983

This Quick Guide is intended as a useful reference for ventilation of **adult and pediatric** patients. It does *not* replace the clinical judgment of a physician nor the content of the ventilator *Operator's Manual*, which should always be available when using the ventilator.

Some functions are optional and are *not* available in all markets.

The graphics shown in this guide may *not* exactly match what you see in your environment.

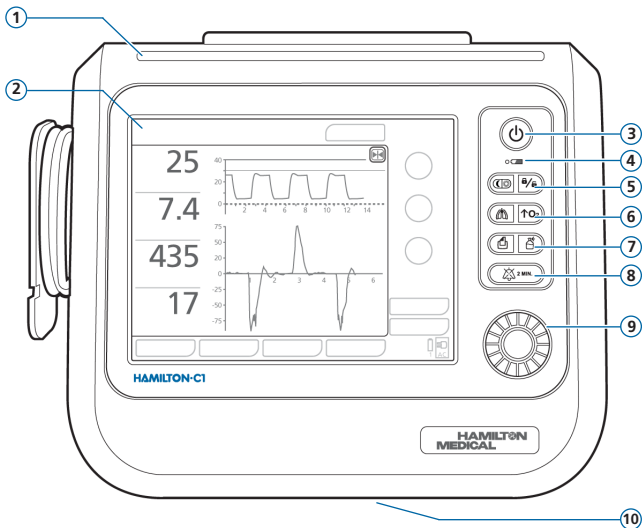











Table of contents

1. HAMILTON-C1 basics.....	4
2. Setting up the ventilator.....	10
3. Configuring patient settings.....	19
4. Performing the preoperational check	20
5. Configuring ventilation settings.....	24
6. Monitoring the patient.....	28
7. Ventilation modes	32
8. Monitoring parameters (ventilator)	34
9. Control parameters	38
Notes.....	40

1. HAMILTON-C1 basics

1.1 Ventilator, front view



- 1 **Alarm lamp.** Lit when an alarm is active.
Red = high priority. Yellow = medium or low priority.
- 2 **Touch screen display**
- 3  **Power/Standby key.** Turns the ventilator on/off; used to enter Standby.
- 4  **Battery charge indicator.** Lit = battery is fully charged. Flashing = battery is charging.
- 5  **Day/Night key.** Switches between Day and Night display brightness setting.
-  **Screen lock/unlock key.** Disables/enables the touch screen (for example, for cleaning).
- 6  **Manual breath key.** Delivers a mandatory breath or a prolonged inspiration.
-  **O2 enrichment key.** Delivers a maximum of 100% oxygen for a set time. Also used for suctioning.
- 7  **Print screen key.** Saves a screenshot of the current display to a USB storage device.
-  **Nebulizer key.** Activates the pneumatic nebulizer for 30 minutes. Press the key again to turn nebulization off.
- 8  **Audio pause key.** Pauses the audible alarm for 2 minutes. Press the key again to cancel the Audio pause.
- 9 **Press-and-turn (P&T) knob.** Used to select and adjust settings.
- 10 **Expiratory valve bleed port.** *Do not obstruct.*

1. HAMILTON-C1 basics

1.2 Ventilator, side view with gas connections

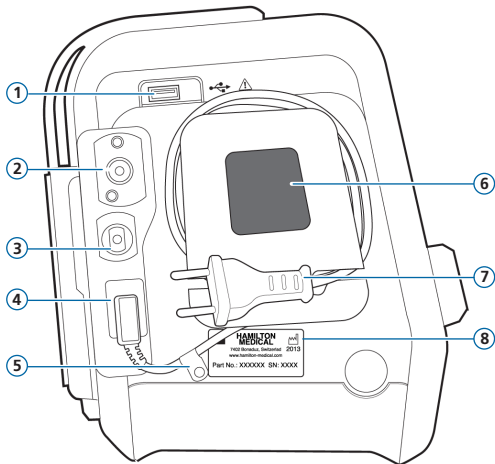

- 1 USB port
- 2 High-pressure oxygen DISS or NIST inlet fitting
- 3 Low-pressure oxygen fitting
- 4 Power socket
- 5 AC power cord retaining clip
- 6 Cooling air intake and dust filter
- 7 AC power cord
- 8 Serial number label

1. HAMILTON-C1 basics

1.3 Ventilator, side view with breathing circuit connections

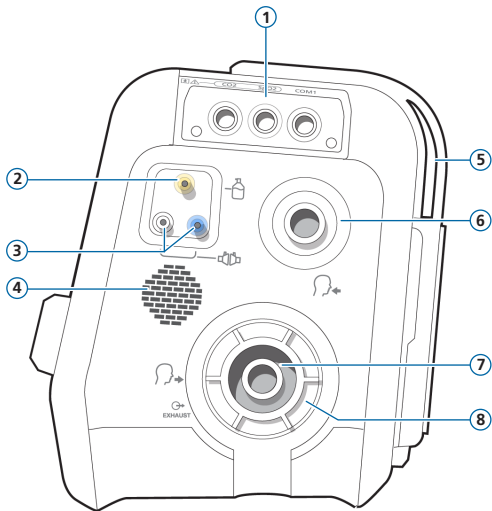

- 1 Communication board (optional)
- 2 Pneumatic nebulizer port
- 3 Flow sensor connection ports
- 4 Loudspeaker
- 5 Cooling air outlet
- 6 *To patient* inspiratory port
- 7 *From patient* expiratory port
- 8 Expiratory valve set

1. HAMILTON-C1 basics

1.4 Main display

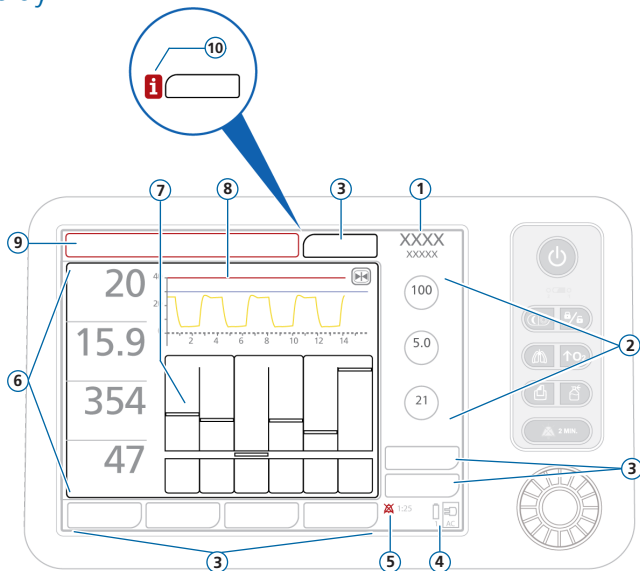

- 1 Active mode and patient group.** Shows the active mode and selected patient group.
- 2 Controls.** Controls for the active mode.
- 3 Window buttons.** Open the Modes, Monitoring, Tools, Events, System, Alarms, Controls windows. The Controls window provides access to patient, SpeakValve, and Apnea settings.
- 4 Power source.** Shows the active and available power sources.
- 5 Audio pause indicator.** Shows that Audio pause is enabled and how much time remains before the audible alarm sounds.
- 6 Main monitoring parameters (MMPs).** Configurable monitoring data.
- 7 Graphic panel.** Real-time waveforms, loops, trends, Intelligent panels.
- 8 Paw waveform.** The pressure/time (Paw) waveform is always displayed.
- 9 Message bar.** Displays alarms and other messages.
- 10 i-icon.** Displayed when there are unreviewed alarms.

2. Setting up the ventilator

2.1 Installing the expiratory valve set

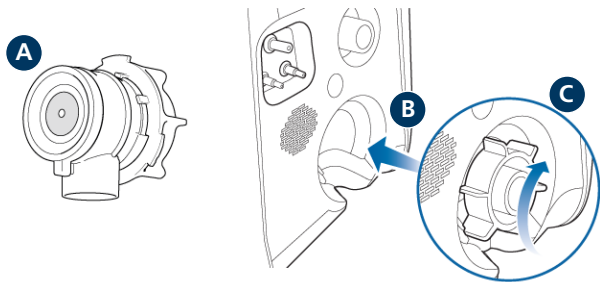

To install the expiratory valve set

- 1 Remove the safety cover.
- 2 Ensure the membrane is properly aligned with the expiratory valve housing, and the metal plate faces up (A).
- 3 Position the expiratory valve set in the expiratory port (B) and twist the locking ring clockwise until it locks into place (C).

2. Setting up the ventilator

2.2 Connecting a breathing circuit (humidification/HMEF)

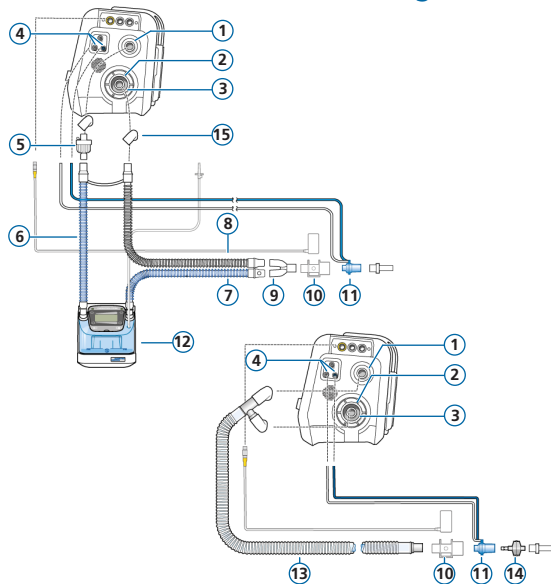

- 1 To patient inspiratory port
- 2 From patient expiratory port
- 3 Expiratory valve set
- 4 Flow sensor connection ports
- 5 Bacteria filter
- 6 Inspiratory limb to humidifier
- 7 Heated inspiratory limb with temperature sensor, to patient
- 8 Heated expiratory limb
- 9 Y-piece
- 10 CO2 sensor/adaptor
- 11 Flow sensor
- 12 Humidifier
- 13 Coaxial inspiratory/expiratory limb
- 14 HMEF
- 15 Adapters

2. Setting up the ventilator

2.3 Connecting a breathing circuit (High flow oxygen)

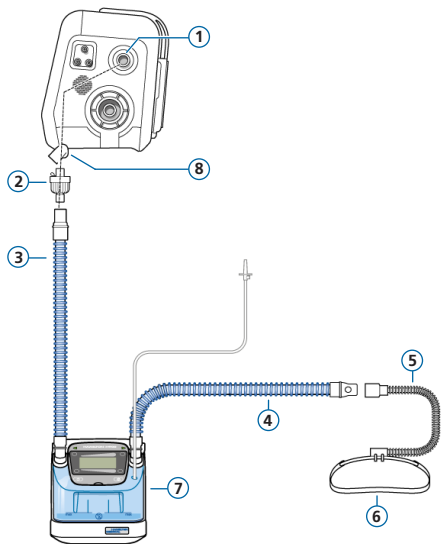

- 1 To patient inspiratory port
- 2 Bacteria filter
- 3 Inspiratory limb to humidifier
- 4 Heated inspiratory limb with temperature sensor, to patient
- 5 Nasal cannula
- 6 Attachment strap
- 7 Humidifier
- 8 Adapters (various)

High flow oxygen is not available in all markets.

2. Setting up the ventilator

2.4 Connecting a pneumatic nebulizer (optional)

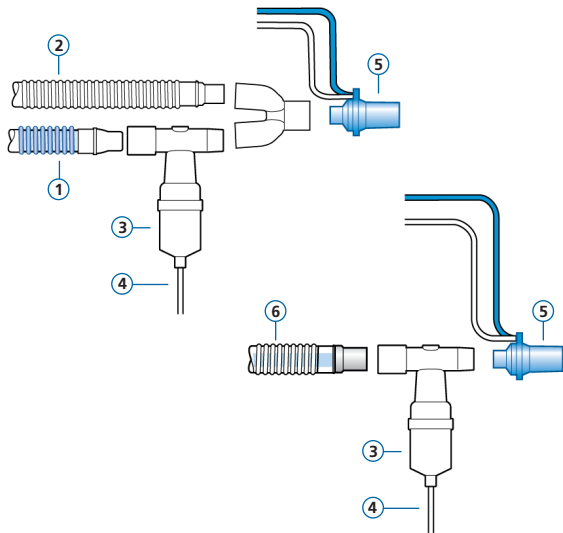

- 1 Inspiratory limb
- 2 Expiratory limb
- 3 Nebulizer (example)*
- 4 Connection tube to ventilator
- 5 Flow sensor
- 6 Coaxial breathing circuit

Inspiratory bacteria filter not shown.

* Place the nebulizer according to your institution's protocol.

2. Setting up the ventilator

2.5 Connecting a mainstream CO2 sensor

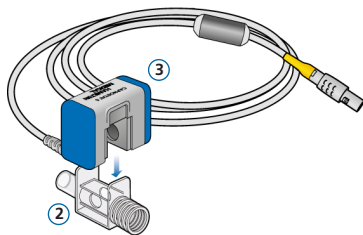
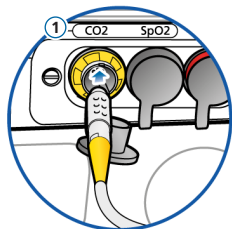

Attaching the CO2 sensor to the airway adapter

- 1 Connect to CO2 port on the ventilator
- 2 Airway adapter
- 3 CO2 sensor

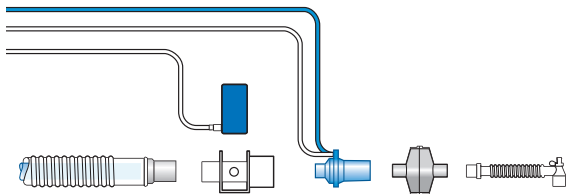

Connecting the CO2 sensor/ adapter* to the breathing circuit

- ▶ See the diagram to the left.

* Connect the CO2 sensor in front of or behind the flow sensor, according to your institution's protocol.

2. Setting up the ventilator

2.6 Connecting an SpO₂ pulse oximeter (Masimo SET)

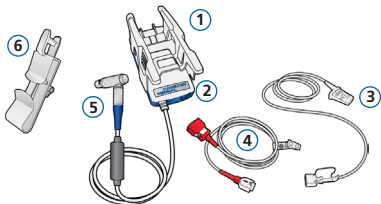

Masimo SET pulse oximeter components*

- 1 Adapter containing the oximeter hardware
- 2 Cable connection ports
- 3 Sensor and cable
- 4 Patient cable (connects to adapter and sensor)
- 5 Adapter cable (connects the adapter to the SpO₂ port on the ventilator communication board)
- 6 Sensor cable holder

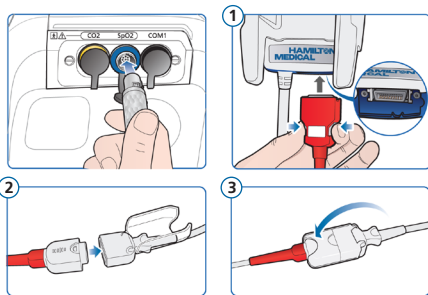

To connect the cables*

- ▶ Connect the patient and sensor cables to the ventilator as shown.

* Your cables may look different from those shown.

2. Setting up the ventilator

2.7 Connecting an SpO2 pulse oximeter (Nihon Kohden)

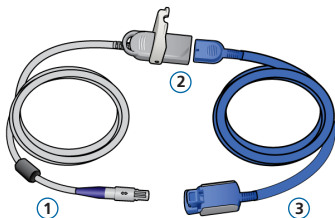

Nihon Kohden pulse oximeter components

- 1 Adapter cable (connects the adapter to the SpO2 port on the ventilator)
- 2 Adapter
- 3 Sensor and sensor cable

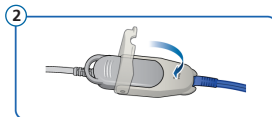
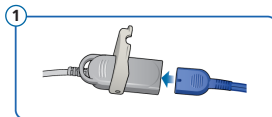
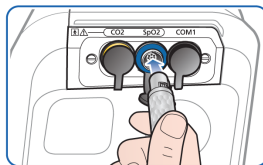

To connect the cables

- ▶ Connect the patient and sensor cables to the ventilator as shown.

2. Setting up the ventilator

2.8 Turning on the ventilator

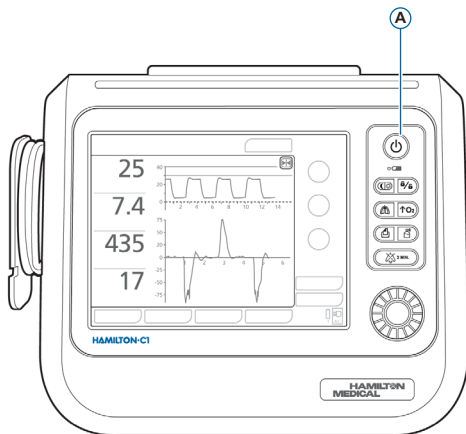

To turn on the ventilator

- 1 Connect the ventilator to AC power and oxygen supply.
- 2 Assemble and connect the patient breathing circuit.
- 3 Press  (Power/Standby) (A).

The ventilator runs a self-test and, when complete, displays the **Standby** window.

Use the ventilator only if it passes all tests.

2. Setting up the ventilator

2.9 Enabling sensor monitoring

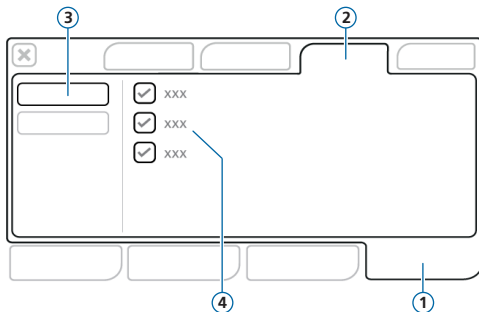

- 1 System
- 2 Sensors
- 3 On/Off
- 4 Sensor options (O2, CO2, SpO2)

To enable sensor monitoring

- 1 Touch **System** > **Sensors** > **On/Off**.
- 2 Select the O2 sensor*, CO2 sensor**, and/or SpO2** sensor checkboxes as required, and close the window.

*By default, the O2 sensor is enabled. **If the option is installed and activated.

3. Configuring patient settings

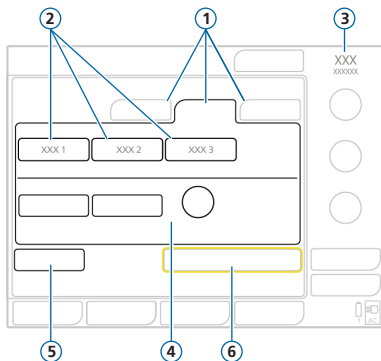

- 1 Patient group: **Neonatal**, **Adult/Ped**, **Last patient**
- 2 Quick setups
- 3 Selected mode and patient group
- 4 Sex, Patient height, calculated IBW
- 5 Preop check
- 6 Start ventilation

To select the patient group and specify patient data

- 1 Touch **Adult/Ped**, **Neonatal**, or **Last patient** (uses the last-specified settings).
- 2 If **Adult/Ped** is selected, set the patient height. The device calculates the ideal body weight (IBW).
- 3 Touch **Preop check** to perform the preoperational check.

4. Performing the preoperational check

4.1 Tightness test

Perform these steps disconnected from the patient.
Prompts are provided in the System > Tests & Calib window.

Step one

- 1 Do either of the following:
 - Touch **System > Tests & Calib**.
 - In the Standby window, touch **Preop check**.
- 2 Touch **Tightness** to perform the tightness test.
- 3 When prompted, block the patient end of the breathing circuit.
- 4 Hold until instructed to stop on the display.

Pass  or fail  and date/time of the completed test are displayed.

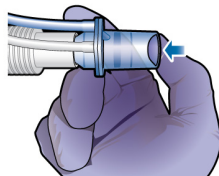
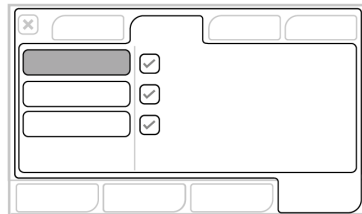



4. Performing the preoperational check

4.2 Calibrating the flow sensor

Step two

- 1 Touch **Flow sensor** to calibrate the flow sensor.
Calibration starts automatically.
- 2 When prompted, attach the calibration adapter to the flow sensor and flip them both 180° so the adapter is directly connected to the limb (as shown below to the right).
Calibration starts automatically.
- 3 When prompted, flip the flow sensor/adapter 180° again, so the flow sensor is directly connected to the limb, and remove the calibration adapter.

Pass  or fail  and date/time of completed test are displayed.

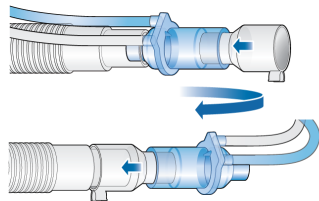
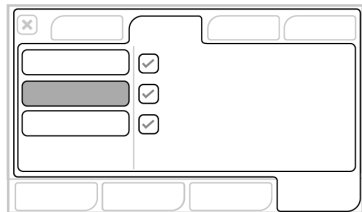

4. Performing the preoperational check

4.3 O2 sensor calibration, alarm tests

Step three

- 1 If an **✘** is displayed next to O2 sensor, touch the **O2 sensor** button to calibrate the sensor.
- 2 If the O2 sensor calibration needed alarm is generated, repeat the calibration.

Step four

- ▶ Test the alarms to ensure proper operation as described in your ventilator *Operator's Manual*.

When calibration and tests are complete, the ventilator is ready for use.

4. Performing the preoperational check

4.4 If the preoperational check fails

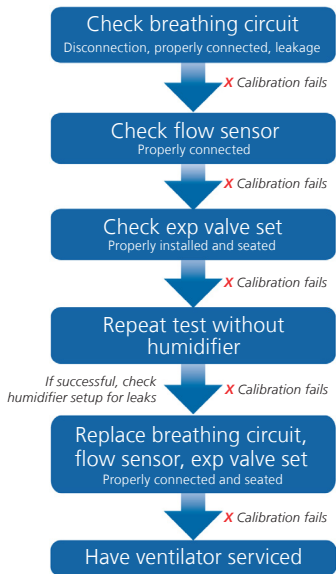

5. Configuring ventilation settings

5.1 Selecting a mode

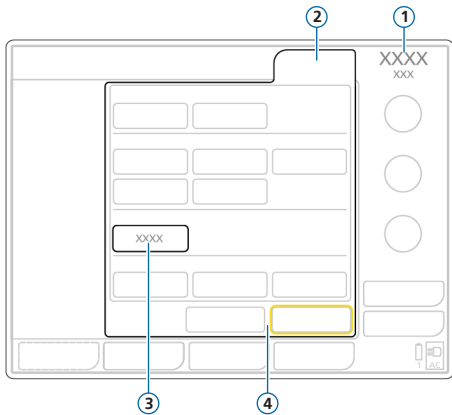

- 1 Active mode and patient group
- 2 Modes button
- 3 New mode
- 4 Confirm/Cancel buttons

To change the mode

- 1 Touch **Modes**.
The Modes window opens.
- 2 Touch the desired ventilation mode.
- 3 Touch **Confirm**.
The Controls window opens.
- 4 Review and adjust settings in the Basic and More windows.
- 5 Touch **Confirm**.

The mode and settings become active.

*The **Confirm/Cancel** buttons are only displayed when selecting a new mode.*

5. Configuring ventilation settings

5.2 Reviewing and adjusting mode controls

Controls window

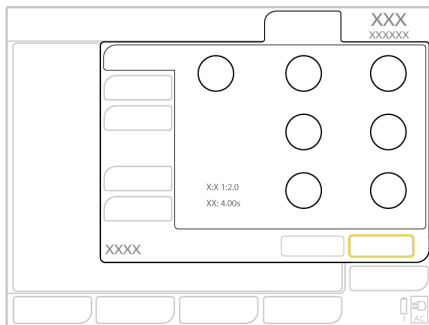

Adjust controls at any time during ventilation.

For details about control settings, see your ventilator *Operator's Manual*.

To adjust settings

- 1 Touch **Controls**.
The Controls > Basic window opens.
- 2 Adjust control settings as needed.
- 3 Touch **More** to access additional controls and make changes as needed.

To start ventilating the patient

- ▶ Touch **Start ventilation** or press  (Power/Standby) to start ventilating the patient.

To stop ventilation and enter Standby

- 1 Press  (Power/Standby).
- 2 In the confirmation window, touch **Activate standby**.

5. Configuring ventilation settings

5.3 Reviewing and adjusting alarm limits

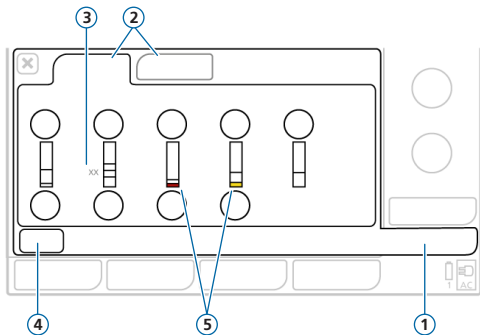

- 1 Alarms
- 2 Limits 1, 2
- 3 Current monitored value
- 4 **Auto** button
- 5 Red or yellow bar (depending on alarm priority) indicates monitored value is out of range.

To review adjustable alarm limits

- 1 Touch **Alarms**.

The Alarms > Limits 1 window opens.

- 2 Set alarm limits as appropriate.

Changing the **High Pressure** and high Vt alarm limits may affect ventilation. See next page.

High pressure alarm limit

The ventilator uses the high Pressure alarm limit minus 10 cmH₂O as a safety boundary for its inspiratory pressure adjustment, and does not exceed this value. An exception is Sigh breaths, when the ventilator may apply inspiratory pressures 3 cmH₂O below the high Pressure alarm limit.

High Pressure alarm limit (1)

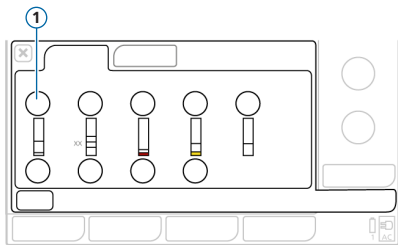

High Pressure alarm limit (1)

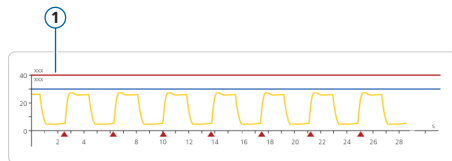

High Vt alarm limit

Inspiratory volume is limited to 150% of the set high Vt alarm limit. Changing the high Vt alarm limit may limit the inspiratory volume. Volume limitation is disabled in noninvasive modes.

6. Monitoring the patient

6.1 Reviewing patient data

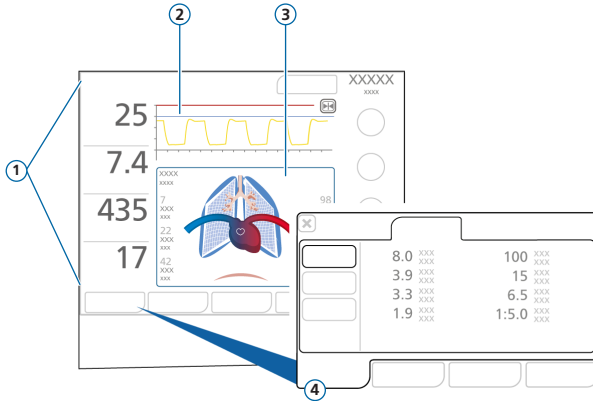

- 1 Main monitoring parameters (MMP), configurable
- 2 Pressure/time (Paw) waveform, nonconfigurable
- 3 Graphic display showing Dynamic Lung, configurable
- 4 Monitoring window, shows all available monitoring data

The main display provides an at-a-glance overview of the patient's data.

6. Monitoring the patient

6.2 The Dynamic Lung

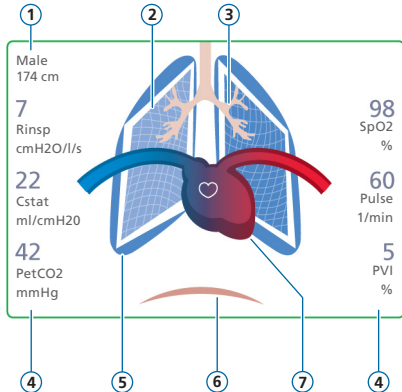

- 1 Sex, height
- 2 Real-time representation of lung compliance
- 3 Real-time representation of airway resistance
- 4 Parameter values
- 5 Real-time representation of breaths and tidal volume
- 6 Patient trigger (diaphragm)
- 7 Heart and pulse display*

Visualizes in real-time:

- Tidal volume
- Lung compliance
- Resistance
- Patient triggering

The lungs expand and contract in synchrony with patient breaths.

When all values are within the specified ranges, the panel is framed in green.

* When SpO2 activated and sensor connected.

6. Monitoring the patient

6.3 Dynamic Lung: Display of resistance and compliance

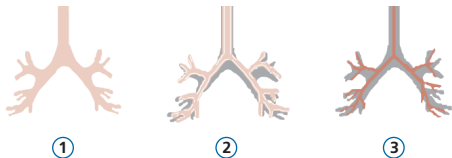

- 1 Normal resistance
- 2 Moderate resistance
- 3 High resistance

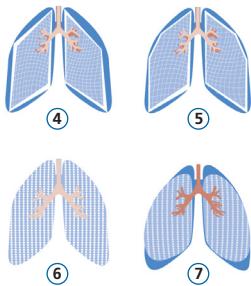

- 4 Very low compliance
- 5 Low compliance
- 6 Normal compliance
- 7 High compliance

6. Monitoring the patient

6.4 Reviewing alarms

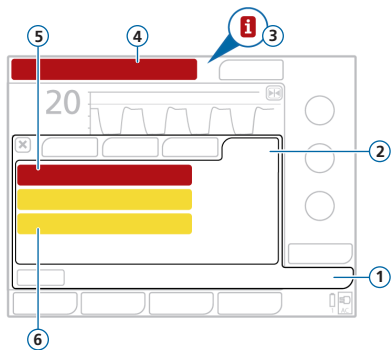

- 1 Alarms
- 2 Buffer
- 3 i-icon (not displayed with active alarms)
- 4 Message bar with alarm
- 5 High-priority alarm (red)
- 6 Medium- or low-priority alarm (yellow)

The *alarm buffer* displays *active* alarms. Active alarm messages also alternate in the *message bar*.

To review active alarms

Do either of the following:

- Touch the message bar.
- Touch **Alarms > Buffer**.

To review previous (inactive) alarms

Do either of the following:

- Touch the i-icon.
- Touch **Alarms > Buffer**.

7. Ventilation modes

Mode	Description
APVcmv / (S)CMV+	<i>Adaptive pressure ventilation with controlled mandatory ventilation.</i> Breaths are mandatory, volume targeted, pressure regulated, variable flow, and time cycled.
APVsimv / SIMV+	<i>Adaptive pressure ventilation with synchronized intermittent mandatory ventilation.</i> Volume-targeted mandatory breaths can be alternated with pressure-supported spontaneous breaths.
PCV+	<i>Pressure-controlled ventilation.</i> Breaths are pressure controlled and mandatory.
PSIMV+	<i>Pressure-controlled synchronized intermittent mandatory ventilation.</i> Mandatory breaths are pressure controlled. Mandatory breaths can be alternated with pressure-supported spontaneous breaths.
DuoPAP	<i>Duo positive airway pressure.</i> Mandatory breaths are pressure controlled. Spontaneous breaths can be triggered at both pressure levels. Rate and inspiratory time are set.
APRV	<i>Airway pressure release ventilation.</i> Spontaneous breaths can be continuously triggered. The pressure release between the levels contributes to ventilation. T high and T low settings determine the Rate .
SPONT	<i>Spontaneous mode.</i> Every breath is spontaneous, with or without pressure-supported spontaneous breaths.
ASV	<i>Adaptive support ventilation.</i> Operator sets %MinVol , PEEP , and Oxygen . Frequency, tidal volume, pressure , and I:E ratio are based on physiological input from the patient.
NIV	<i>Noninvasive ventilation.</i> Every breath is spontaneous.
NIV-ST	<i>Spontaneous/timed noninvasive ventilation.</i> Every breath is spontaneous as long as the patient is breathing above the set Rate . A backup Rate can be set for mandatory breaths.

Mode	Description
nCPAP	<i>Neonatal only mode.</i> Demand flow Nasal Continuous Positive Airway Pressure.
nCPAP-PC	<i>Neonatal only mode.</i> Breaths are pressure controlled and mandatory.

Additional information is available in your ventilator *Operator's Manual*.

8. Monitoring parameters (ventilator)

Parameter	Description
AutoPEEP	The difference between the set PEEP and the calculated total PEEP within the lungs. AutoPEEP is the abnormal pressure generated by air “trapped” in the alveoli due to inadequate lung emptying. Ideally, it should be zero. AutoPEEP is calculated using the LSF method applied to the entire breath.
Control Flow	The set flow of gas to the patient when using HiFlowO2.
Cstat	Static compliance of the respiratory system, including lung and chest wall compliances, calculated using the LSF method. Cstat can help diagnose changes in elastic characteristics of the patient’s lungs.
Exp Flow	Peak expiratory flow.
ExpMinVol/ MinVol NIV	Expiratory minute volume. The moving average of the monitored expiratory volume per minute over the last 8 breaths. ExpMinVol changes to MinVol NIV in noninvasive modes. MinVol NIV is an adjusted parameter taking leakage into account.
fControl	Mandatory breath frequency.
FetCO2	Fractional end-tidal CO2 concentration. Permits assessment of PaCO2 (arterial CO2). Note that it is inaccurate in pulmonary embolism.
Flow	In nCPAP mode, this value is the average flow, updated every second. In nCPAP-PC mode, this value is the average flow during expiration, updated every breath.
fSpont	Spontaneous breath frequency.
fTotal	Total breathing frequency.
I:E	Inspiratory:expiratory ratio. Ratio of the patient’s inspiratory time to expiratory time for every breath cycle. This includes both mandatory and spontaneous breaths. I:E may differ from the set I:E ratio if the patient breathes spontaneously.

Parameter	Description
IBW	Ideal body weight. A calculated value using height and sex, for adult and pediatric patients.
Insp Flow	Peak inspiratory flow, spontaneous or mandatory. Measured every breath.
MVSpont/ MVSpont NIV	Spontaneous expiratory minute volume. The moving average of the monitored expiratory volume per minute for spontaneous breaths, over the last 8 mandatory and spontaneous breaths. In noninvasive ventilation modes, MVSpont is replaced by MVSpont NIV. MVSpont NIV is an adjusted parameter taking the leakage into account.
Oxygen	Oxygen concentration of the delivered gas.
P01	Airway occlusion pressure. The pressure drop during the first 100 ms when a breath is triggered. P0.1 indicates the patient's respiratory drive and patient inspiration effort. Applies to patient-triggered breaths.
PEEP/CPAP	Monitored PEEP/CPAP. The airway pressure at the end of exhalation. Measured PEEP/CPAP may differ slightly from the set value, especially in spontaneously breathing patients.
PetCO2	End-tidal CO2 pressure. The maximum partial pressure of CO2 exhaled during a tidal breath (just before the start of inspiration). It represents the final portion of air that was involved in the exchange of gases in the alveolar area, thus providing a reliable index of CO2 partial pressure in the arterial blood under certain circumstances.
Pinsp	Inspiratory pressure, the automatically calculated target pressure (additional to PEEP) applied during the inspiratory phase.
Pmean	Mean airway pressure. The absolute pressure, averaged over the breath cycle.
Ppeak	Peak airway pressure. The highest pressure during the previous breath cycle. It is influenced by airway resistance and compliance. Ppeak may differ noticeably from alveolar pressure if airway resistance is high. This value is always displayed.

8. Monitoring parameters (ventilator)

Parameter	Description
Pplateau	Plateau or end-inspiratory pressure. The pressure measured at the end of inspiration when flow is at or close to zero. Used as a rough representation of alveolar pressure. Pplateau is displayed for mandatory and time-cycled breaths.
PTP	Inspiratory pressure time product. PTP is valid for patient-initiated breaths only, and indicates work by the patient to trigger the breath.
RCexp	Expiratory time constant. The rate at which the lungs empty.
Rinsp	Resistance to inspiratory flow caused by the endotracheal tube and the patient's airway during inspiration.
RSB	Rapid shallow breathing index. The total breathing frequency (fTotal) divided by the exhaled tidal volume (VTE).
TE	Expiratory time. In mandatory breaths, TE is measured from the start of exhalation until the set time has elapsed for the switch to inspiration. In spontaneous breaths, TE is measured from the start of exhalation, as dictated by the ETS setting, until the patient triggers the next inspiration. TE may differ from the set expiratory time if the patient breathes spontaneously.
TI	Inspiratory time. In mandatory breaths, TI is measured from the start of breath delivery until the set time has elapsed for the switch to exhalation. In spontaneous breaths, TI is measured from the patient trigger until the flow falls to the ETS setting for the switch to exhalation. TI may differ from the set inspiratory time if the patient breathes spontaneously.
VLeak/ MVLeak	Due to the leakage at the patient interface, displayed exhaled volumes in the noninvasive modes can be substantially smaller than the delivered volumes. The flow sensor measures the delivered volume and the exhaled tidal volume; the ventilator displays the difference as VLeak in %, and as MVLeak in l/min, averaged over the past 8 breaths.
Vt/IBW	Tidal volume is calculated according to ideal body weight (IBW) for adult/pediatric patients and according to the actual body weight for neonatal patients.

Parameter	Description
VTE/ VTE NIV	Expiratory tidal volume, the volume exhaled by the patient. If there is a gas leak on the patient side, the displayed VTE may be less than the tidal volume the patient actually receives.
VTEspont	Spontaneous expiratory tidal volume, the volume exhaled by the patient. Only displayed for spontaneous breaths.
VTI	Inspiratory tidal volume, the volume delivered to the patient, determined from the flow sensor measurement.

Additional information about monitoring parameters is available in your ventilator *Operator's Manual*.

9. Control parameters

Parameter	Description
%MinVol	Percentage of minute volume to be delivered in ASV mode. The ventilator uses the %MinVol, Pat. height, and Sex settings to calculate the target minute ventilation.
Apnea Backup	A function that provides ventilation after the adjustable apnea time passes without breath attempts.
ETS	Expiratory trigger sensitivity. The percentage of peak inspiratory flow at which the ventilator cycles from inspiration to exhalation.
Flow	In HiFlowO2, Flow is the continuous and constant flow of medical gas to the patient in liters per minute.
Flow trigger	The patient's inspiratory flow that triggers the ventilator to deliver a breath.
I:E	Ratio of inspiratory time to expiratory time as determined by the control settings. Applies to mandatory breaths, when the device is configured in this way.
Oxygen	Oxygen concentration to be delivered.
P high	The high pressure setting in APRV and DuoPAP modes. Absolute pressure, including PEEP.
P low	The low pressure setting in APRV.
Pasvlimit	The maximum pressure to apply in ASV mode. Changing Pasvlimit or the high Pressure alarm setting automatically changes the other. The upper Pressure alarm limit is always 10 cmH2O greater than Pasvlimit.
Pat. height	Patient height. Used in calculation of the ideal body weight (IBW), which is used in calculations for ASV and startup settings for adult and pediatric patients.
Pcontrol	Pressure (additional to PEEP/CPAP) to apply during the inspiratory phase in PCV+ and PSIMV+ modes.
PEEP/CPAP	Positive end expiratory pressure.
Pinsp	Pressure (additional to PEEP/CPAP) to apply during the inspiratory phase in PSIMV+Psync, and NIV-ST modes.

Parameter	Description
P-ramp	Pressure ramp. Time required for inspiratory pressure to rise to the set (target) pressure.
Psupport	Pressure support for spontaneous breaths in SPONT, NIV, APVsimv, PSIMV+, and DuoPAP modes.
Rate	Respiratory frequency or number of breaths per minute.
Sigh	Breaths delivered at a regular interval (every 50 breaths) at a pressure up to 10 cmH ₂ O higher than non-sigh breaths, as allowed by the upper Pressure alarm setting.
T high	Length of time at the higher pressure level, P high, in DuoPAP and APRV modes.
T low	Length of time at the lower pressure level, P low, in APRV mode.
Ti	Inspiratory time, the time to deliver the required gas for inspiration at the Pcontrol setting. Used with Rate to set the breath cycle time. Applies in PCV+, APVcmv, APVsimv, PSIMV+, and NIV-ST modes.
Ti max	Maximum inspiratory time for flow-cycled (pressure support) breaths in NIV, NIV-ST, and SPONT in neonatal modes.
Vt	Tidal volume delivered during inspiration in APVcmv, and APVsimv modes.
Weight	Actual body weight. Used only with neonates.

Additional information about control parameters is available in your ventilator *Operator's Manual*.

Notes

Notes



Intelligent Ventilation since 1983

Manufacturer:

Hamilton Medical AG

Via Crusch 8, 7402 Bonaduz, Switzerland

 +41 (0)58 610 10 20

info@hamilton-medical.com

www.hamilton-medical.com

10086060/00

Specifications are subject to change without notice. Some features are options. Not all features are available in all markets. For all proprietary trademarks (®) and third-party trademarks (®) used by Hamilton Medical AG, see www.hamilton-medical.com/trademarks. © 2019 Hamilton Medical AG. All rights reserved.